

RADAR TRACKING GROUP



The RTG incorporates complex coherent demodulation (I and Q processing) performed digitally for improved orthogonality, and provides digital filtering on all four channels. The digital filters are programmed to match selected CW pulse widths up to 25 usec in length, as well as perform pulse compression on 13 MHz LFM pulsewidths of 12.5 and 25 useconds.

The dual gate digital range tracker provides independent range tracker operation on two targets within the beam. The target position is computed based on centroid, lead-edge or trail-edge processing. The type-II track loop operates in software using floating-point format to avoid data granularity problems frequently encountered in hardware track loops.

Radar Tracking Group (RTG) Assembly 8000747-10.

Target acquisition is supported on full-range or interval video, using a digital N-out-of-M threshold for a reduced false-alarm rate.

The RTG accepts four channels of 30 MHz IF inputs (SUM1, SUM2, Up/Down, and Left/Right) from an external RF receiver and processes these signals.

As depicted in the photo, the RTG is housed in three racks. The Unit 1, Waveform Generator (WFG) and the Unit 2, IF Receiver/Digital Signal Processor (IF Rx/DSP) racks are full height (86"). The Unit 3, Operator Communications (OPCOM) rack is a smaller, portable, roll-around rack (60"). An A-Scope monitor is also provided and can be provided in either a tabletop or rack mount configuration.

Functionally, the RTG, as depicted in below block diagram, comprises an IF receiver, a Digital Signal Processor, and a Waveform Generator.

RTG Subsystem Block Diagram

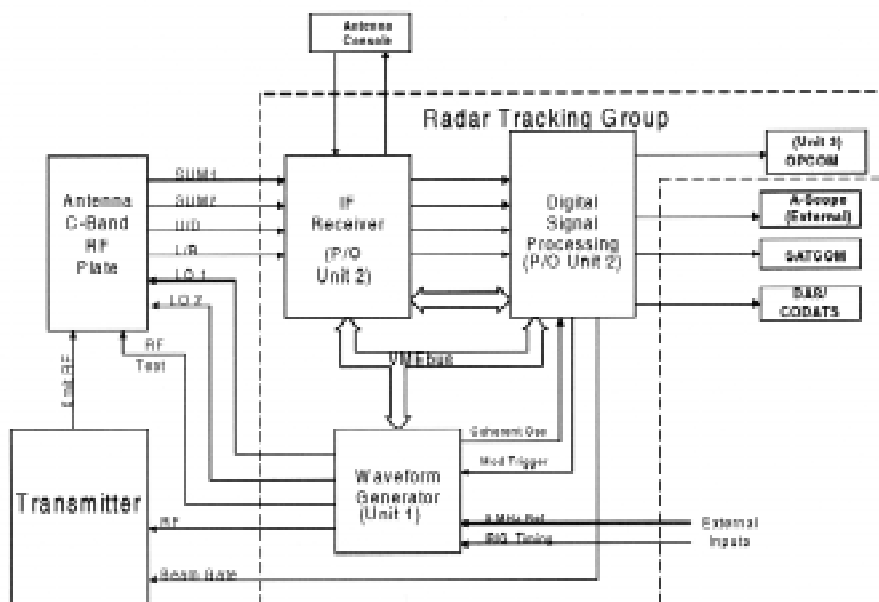

THE RTG PROVIDES :

- IF RECEIVER AND RANGE TRACKER FUNCTIONS
- VIDEO DISPLAY GENERATION
- COHERENT WAVEFORM GENERATION
- C-BAND LO SIGNALS TO THE RF RECEIVER.
- C-BAND RF EXCITATION TO THE RADAR TRANSMITTER.

FEATURES

- Four-channel dual gate processing, 30 MHz input
- Two rack system, third rack portable maintenance terminal
- Remote control via dual fiber optic links
- Remote control
- Local control for maintenance
- Built-In Test and diagnostic performance monitoring
- Linear FM with digital decompression
- VME based
- SATCOM Interface
- Detected video output formats:
 - Range Amplitude
 - Range Time Intensity
 - Composite Log
 - I/Q Signals @ Standard S-VHS levels
- Dual target - Centroid, lead-edge, trail-edge track gates, independently selectable (Beacon and Skin)
- Each gate independently provides:
 - Track Range
 - Velocity
 - Acceleration
 - Doppler offsets at IF
- System supports solar power measurements, boresight/star alignments, and measured noise temperature
- IRIG B-000 signal IAW IRIG 200-89 external time base inputs
- Doppler processing for Coherent-beacon or skin and Compressed-skin tracks
- Angle errors are provided by primary gate or secondary gate data. Selectable.
- 15 Minute Warm-up max
- Simulated Target Generator, internal.
- Selectable STC curves: $1/R$, $1/R^2$, $1/R^3$, $1/R^4$

CAPABILITIES

- Coherent C-band Source with Linear FM capability, programmable to within 4 Hz accuracy, ± 2 Hz resolution, using external 5 MHz reference standard.
- 5.4 GHz to 5.9 GHz
- Typical RF output 50Ω +27 dBm (0.1 dB steps, software adjustable) – 1.5:1 VSWR
- Dual, independently controlled LO outputs, 50Ω , Type N connector into a 1.5:1 VSWR @ +27 dBm (0.1 dB steps, software adjustable)
- Secondary RF test probe output. Typical RF output 50Ω , Type N connector into a 1.5:1 VSWR @ +27 dBm (0.1 dB steps, software adjustable) 5.4 GHz to 5.9 GHz
- Pulse Width selections: 0.25ms to 25.0ms selectable at 0.25ms increments
- C-band, RF Drive, duty cycle 0.004 Typical (software adjustable)
- Beam gate, duty cycle 0.0048 Typical (software adjustable)
- Autotrack, Range tracking accuracy ≤ 1 ft/sec @ S/N of 10 dB and Range tracking accuracy ≤ 5 ft/sec @ S/N of 5 dB
- Linear Instantaneous Receiver Dynamic Range 70 dB
- Receiver Dynamic Range >90 dB
- Matched IF Bandwidth with RF loop Gain loss ≤ 0.8 dB
- IF Receiver Noise figure less than 12 dB
- Auto Acquisition, Auto Track, independent gate selection feature for full range or interval gate. Full 32 K mile (nautical) unambiguous track range. Fault detection ratio @ 3 out of 4 hits at slew rate: 80 K yards/sec IF Channel Calibration – Phase Balance of ± 2.5 degrees and an Amplitude of ± 0.25 dB
- Primary input requirements: 120 VAC/60 Hz/30 Amps provided by twist lock AC plugs

For more information, please contact Business Development
Technical Services 557 Mary Esther Cutoff Fort Walton Beach, FL 32548-4090
Telephone (850) 244-7752 Fax (850) 244-7782

BAE SYSTEMS